

## FLTCON-2-24VDC

### Data Sheet



Input Voltage	24VDC
Output Voltage	24VDC
Current Rating total	15A
Current Rating per channel	10A
Number of Channels	2
Feedback Input	Hall Effect Sensor
Duty Cycle	10% (2 min on, 18 min off)
Operational Temperature	5°C to 40°C
Housing Color	Black
Housing Material	POM
Certifications	None
Dimensions (LxWxH)	7.75" x 5.25" x 3.00"
Unit Weight	0.56lbs
Warranty	18 Months

# Dimensions

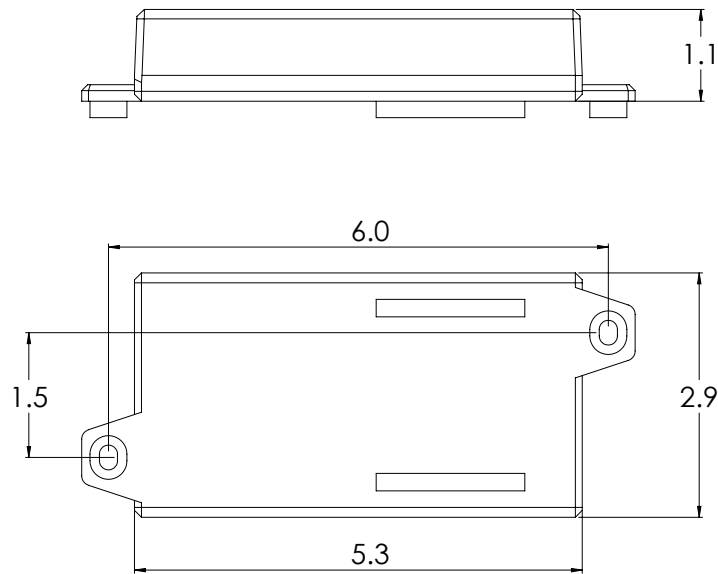

## Operational Procedure

To raise the actuator(s) or column(s), press and hold the UP button. To lower the actuator(s) or column(s), press and hold the DOWN button. The UP and DOWN buttons are momentary controlled. When either directional buttons are released, the actuator(s) or column(s) will stop immediately.

To save a position, move the actuator(s) or column(s) to the desired height. Press the "M" button followed by a number. The LED display will flash an 'S', followed by an 'S - Number'. This will indicate that the position has been saved. To use a preset, press any of the numbered buttons and the actuator(s) or column(s) will begin to move to the preset position. It is important to ensure that no obstacles impede the motion of travel. To stop motion while in travel, press any button. If the connected actuator(s) or column(s) do not function as intended or the LED display flashes "RST", please follow the Reset Procedure outlined below.

## Reset Procedure

To enter the Reset Procedure, press and hold the DOWN button on the Hand Remote until the LED shows "RST" (If you are not using an LED hand remote, hold the DOWN button for about 10 seconds). Release the DOWN button. Press and hold the DOWN button once more until the actuator(s) or column(s) lower completely then slightly rise before coming to a stop. This signals the end of the reset procedure. Release the DOWN button and your system is now ready to use.

If any error message persist after completing the reset procedure, contact us at 1-800-676-6123 or by email at [sales@progressiveautomations.com](mailto:sales@progressiveautomations.com) to receive assistance from our available technicians.

- \*If the height difference between the legs exceeds 1.5 inches, stop the reset procedure & contact us.
- \*If the handset displays 'HOT', let the unit cool down for 20 minutes before starting the reset procedure again.

# Setting Upper & Lower Limits



## Upper Limit

To set the upper limit, use the UP/DOWN buttons to move the table lift to your desired max height position. Once it is at the desired position, press and hold the "M" button until the LED display flashes "S-" once, then release the button. Press and release the button two more times in quick succession. The LED display should then show "999" on the third press and then automatically return to the desired height. The upper limit is now set.

## Lower Limit

To set the lower limit, use the UP/DOWN buttons to move the table lift to your desired minimum height position. Once it is at the desired position, press and hold the "M" until the LED display flashes "S-" once, then release the button. Press and release the button two more times in quick succession. The LED display should then show "000" on the third press and then automatically return to the desired height. The lower limit is now set.

## Removing Limits

To remove the upper and lower limits, use the UP/DOWN buttons to move the desk to any desired position. Press and hold the "M" button until the LED display flashes "S-" once, then release the button. Press and release the button in succession until the display changes to "555"(ignore any other readings). After a few seconds, the display will automatically change back to the numbered height position. Upper and lower limits should now be removed.

\*After the upper and lower limits are set, the previous memory positions (1,2,3,4) may be outside the new range of movement. If this happens, simply reset the memory positions.

\*A Reset procedure requires the desk base to fully retract beyond any lower limit. Please ensure you have proper clearance below the desk base.

\*If you attempt to revise a previously set upper or lower limit and it is outside of the existing range, you will need to remove the original upper/lower limits first.



Troubleshooting Guide		
Problem	Possible Cause	Corrective Action
Remote LED is off.	Low power mode activated	Press any button on the remote and LED will activate.
	Connection issue	Disconnect and reconnect the RJ-45 remote connector. Ensure connection is secure and cable is not damaged.
Lifting columns do not move when motion control buttons are pressed.	Limit switch reached	Follow "Setting Limit Switches" instructions to remove the programmed limit (FLTCON-02 only). If maximum or minimum height limit has been reached, please move the system in the opposite direction.
	Connection issue	Disconnect and reconnect the Lifting Columns, Control Box, AC Power, and Remote.
Lifting columns travel at a significantly slower speed than rated specification.	Weight issue	Ensure weight capacity has not exceeded the maximum load rating.
Unusual noise during travel.	Weight issue	Ensure weight capacity has not exceeded the maximum load rating.
Lifting columns stop abruptly during travel.	Obstacle	Ensure there are no obstacles in the path of the lifting columns. If the movement continues to fail, initiate the Reset Procedure.
Lifting columns are not level.	Out of sync	Disconnect and reconnect all cables (Lifting Column, Control Box, AC Power, and Remote), then initiate the Reset Procedure.

Error Codes (remotes with LED display)		
Error Code	Error Summary	Description
E01	M1 overcurrent protection	All columns stop moving and remote displays E01-E04. Ensure that the total weight capacity of the lifting columns has not been exceeded and that no obstacles obstruct the movement. Press any key and remote will display RST, initiate the Reset Procedure. If the issue persists, disconnect and reconnect all of the lifting columns, including the main power. Repeat the Reset Procedure.
E02	M2 overcurrent protection	
E03	M3 overcurrent protection	
E04	M4 overcurrent protection	
E07	M1 hall error	All columns stop moving and remote displays E07-E10. Ensure that all columns are still properly connected to the control box. Check to see if any cables have been damaged. Press any key and remote will display RST, initiate the Reset Procedure. If the issue persists, disconnect and reconnect all of the lifting columns, including the main power. Repeat the Reset Procedure.
E08	M2 hall error	
E09	M3 hall error	
E10	M4 hall error	
H01	Over heat /duty cycle protection	All columns stop moving, remote displays H01 (if LED screen available). Allow the system to rest for 16 minutes, use normally. Follow the Duty Cycle rating to ensure no issues arise from overheating.